

INTENDED FOR USE BY PROFESSIONAL EQUIPMENT OPERATORS

OPERATING INSTRUCTIONS



908 W. Main • P.O. Box 368
Laurel, MT USA 59044
800-548-7341
406-628-8231
www.WPG.com

 **READ AND UNDERSTAND BEFORE
OPERATING THIS EQUIPMENT**

APPLICABLE TO SERIAL NUMBERS 20210001
AND LATER. FOR EARLIER NUMBERS,
SEARCH WPG'S [ARCHIVE](#).

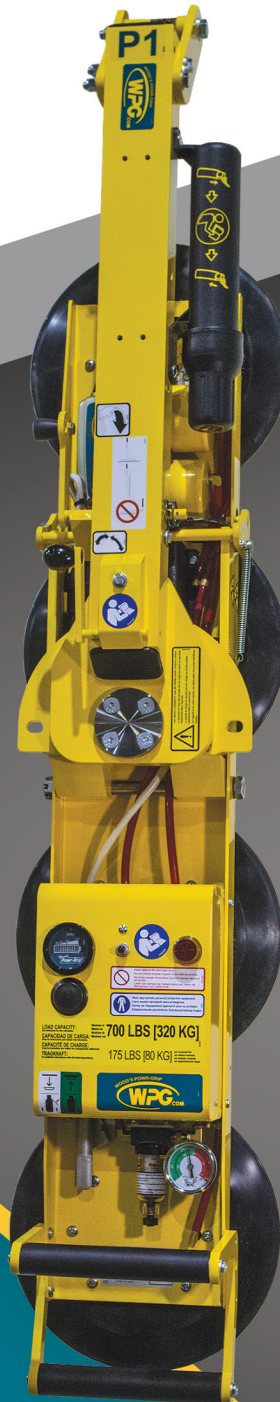

SINGLE-CHANNEL LIFTER, DC-VOLTAGE

Model numbers: P110C04DC, P1HV1104DC,
P11104DC (shown)

Original Instructions © Wood's Powr-Grip Co., Inc.







TABLE OF CONTENTS

SPECIFICATIONS	3
SAFETY	5
OPERATING FEATURES.....	6
ASSEMBLY	7
INTENDED USE	9
LOAD CHARACTERISTICS.....	9
INDIRECT LOADING	10
OPERATING ENVIRONMENT	10
DISPOSAL OF THE LIFTER	10
OPERATION.....	11
BEFORE USING THE LIFTER.....	11
Taking Safety Precautions	11
Performing Inspections and Tests	11
Checking the Battery.....	12
TO USE THE OPTIONAL PAD SHUTOFFS	13
TO ATTACH THE PADS TO A LOAD	14
Positioning the Lifter on the Load.....	14
Sealing the Pads on the Load	15
Reading the Vacuum Gauge.....	15
TO LIFT AND MOVE THE LOAD.....	16
Interpreting the Warning Light and Optional Warning Buzzer	16
Monitoring Vacuum Indicators	16
Controlling the Lifter and Load	17
In Case of a Power Failure.....	17
TO ROTATE THE LOAD	18
TO TILT THE LOAD	19
TO RELEASE THE PADS FROM THE LOAD	20
AFTER USING THE LIFTER.....	20
Storing the Lifter	21
Transporting the Lifter	21
INSPECTIONS AND TESTS	22
INSPECTION SCHEDULE	22

TABLE OF CONTENTS

TESTING	23
Lifter/Load Compatibility Test.....	23
Operational Tests	24
Vacuum Test.....	24
Rated Load Test.....	25
MAINTENANCE	26
VACUUM PAD MAINTENANCE.....	26
Pad-to-Load Friction Coefficient	26
Pad Inspection	26
Pad Cleaning	27
BATTERY RECHARGE.....	28
REPLACEMENT PARTS.....	29
REGISTRATION AND LIMITED WARRANTY	30
TO REGISTER THIS WPG PRODUCT	30
ABOUT THE LIMITED WARRANTY	30
Obtaining Warranty Service or Repair Service.....	30

SPECIFICATIONS

Product Description	Designed for use with hoisting equipment, P1-04DC lifters support loads using vacuum and manipulate loads using manual 180° rotation and manual 90° tilt motions.		
Model Number	P110C04DC	P1HV1104DC	P11104DC
Vacuum Pads: ¹ <i>(4 each, standard rubber)</i>	10" [25 cm] nom. diameter, concave (Model G0750)	10" [25 cm] nom. diameter, lipped (Model HV11)	11" [28 cm] nom. diameter, lipped (Model G3370)
Pad Spread <i>(to outer edges)</i>	49" x 10" [125 cm x 25 cm]	50" x 11" [127 cm x 28 cm]	51" x 12" [130 cm x 30 cm]
 Maximum Load Capacity ²	Per-Pad: 150 lbs [68 kg] Overall: 600 lbs [270 kg]	Per-Pad: 150 lbs [68 kg] Overall: 600 lbs [270 kg]	Per-Pad: 175lbs [80 kg] Overall: 700 lbs [320kg]
 Lifter Weight	90 lbs [41 kg]		
Power System	12 volts DC, 3.5 amps		
Battery Capacity	7 amp-hours		
 Rotation Capability	Manual, 180°, with latching at each ¼ turn (when required)		
 Tilt Capability	Manual, 90°, with automatic latching in vertical position		
 Product Options	<i>Available with Individual Pad Shutoffs.</i> See separate instructions about other options.		
 Operating Elevation	Up to 6,000' [1,828 m]		
 Operating Temperatures	32° — 104° F [0° — 40° C]		
Service Life	20,000 lifting cycles, when used and maintained as intended ³		
ASME Standard BTH-1	Design Category "B", Service Class "O"		
Troubleshooting Guide ⁴	TST-008_DC-CHANNEL-SVS_rev2013-048		





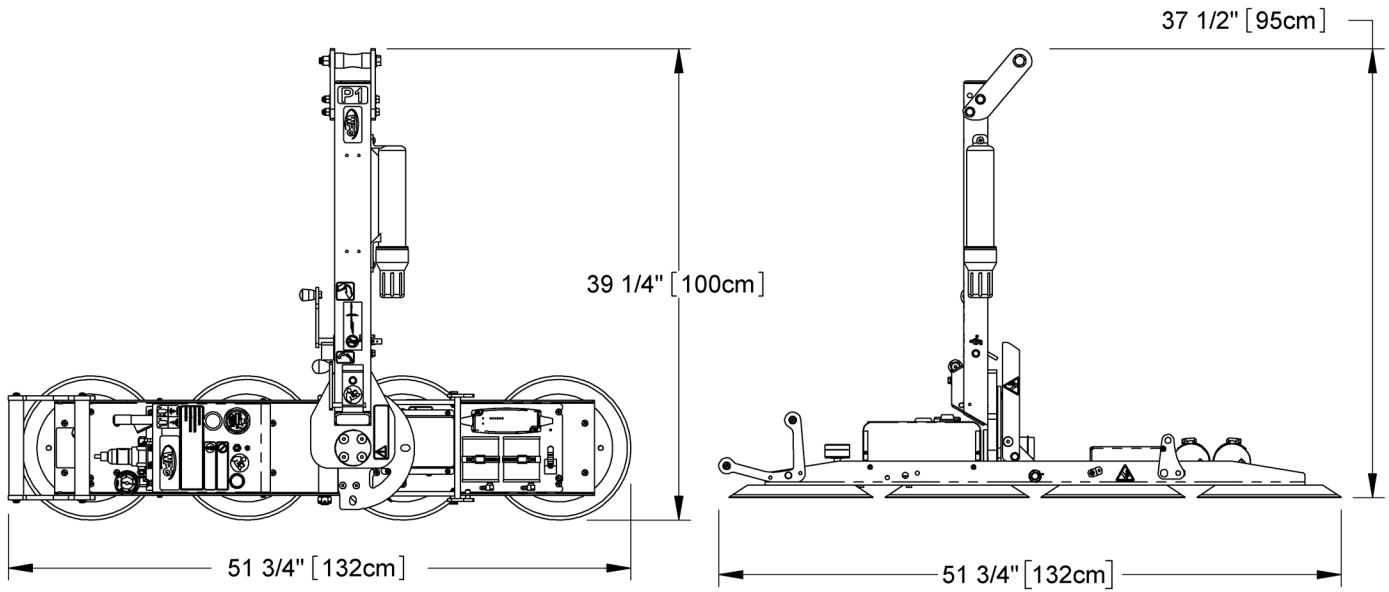
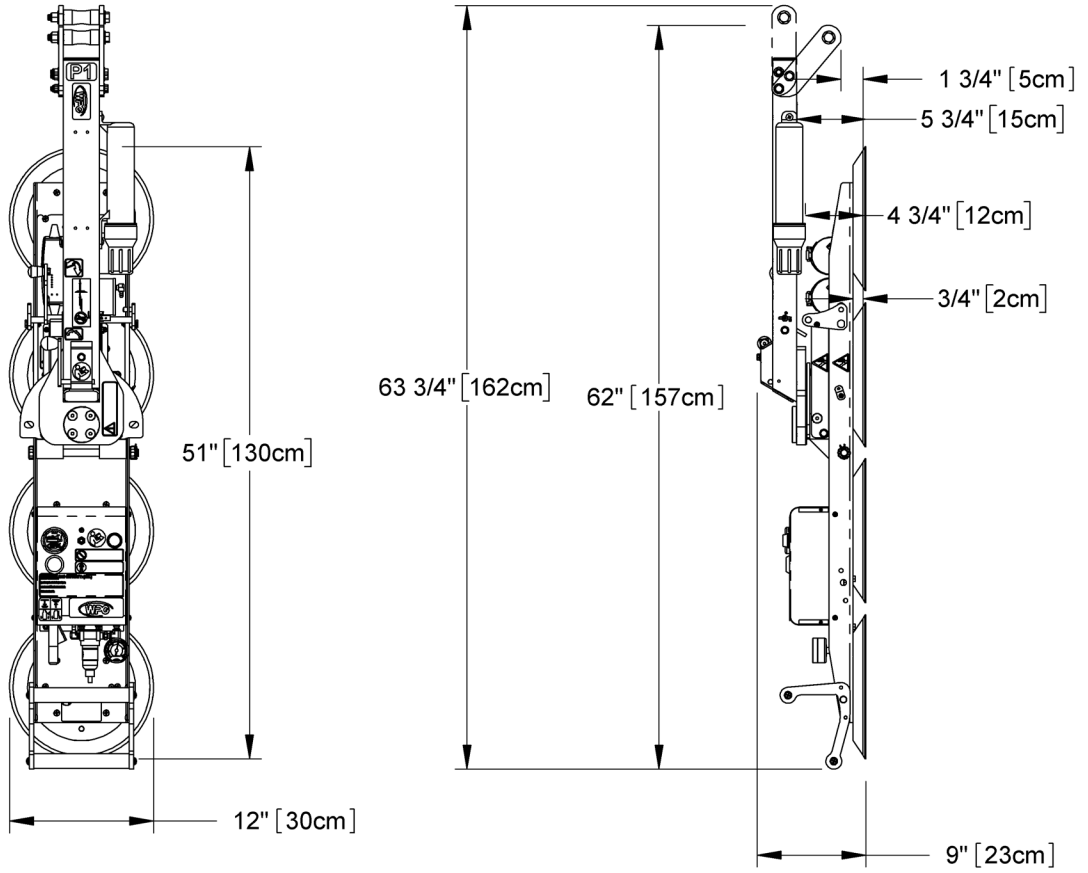















- 1..... Available with other rubber compounds for special purposes (see www.wpg.com).
- 2..... The Maximum Load Capacity is rated at a vacuum of 16" Hg [-54 kPa] on clean, smooth, nonporous flat surfaces with a friction coefficient of 1. Pad compound, load rigidity, strength, surface conditions, overhang, angle, center of gravity and temperature can also affect the lifting capacity. A "qualified person" should evaluate the effective lifting capacity for each use (see definition under "Rated Load Test").
- 3..... Vacuum pads, filter elements and other wear-out items are excluded.
- 4..... To view this guide, click the link at right. Additionally, you can search for your lifter's Model Number at www.wpg.com and select the "Troubleshooting" link on the product page.

SPECIFICATIONS



Note: A standard P11104DC is shown.

SAFETY

-  Wear personal protective equipment that is appropriate for the load material. Follow trade association guidelines.
-  Do not remove or obscure safety labels.
-  Do not make any modifications to the lifter (see “LIMITED WARRANTY”).
-  Use the lifter only in an approved “OPERATING ENVIRONMENT” (see “INTENDED USE”).
-  Make sure to consider all possible effects of “INDIRECT LOADING” on lifting capacity (see “INTENDED USE”).
-  Do not use a lifter that is damaged, malfunctioning, or missing parts.
-  Do not use a lifter if the sealing edge of any vacuum pad is cut or otherwise damaged.
-  Do not use a lifter to lift cracked or broken glass.
-   Do not exceed the Maximum Load Capacity or lift loads the lifter is not designed for (see “INTENDED USE”).
-   Do not use a lifter if the Maximum Load Capacity or any safety label appears to be missing or obscured.
-  Make sure the contact surfaces of the load and vacuum pads are clean before attaching the lifter (see “MAINTENANCE”).
-  Position the vacuum pads correctly on the load before lifting (see “OPERATION”).
-  Do not lift a load if any vacuum indicator shows inadequate vacuum.
-  Keep unauthorized personnel away from the lifter, to avoid injury in case of an unintended load release.
-  Do not touch the vacuum release controls during a lift.
-  Do not allow people to ride on the lifter or the load.
-  Do not lift a load higher than necessary or leave suspended loads unattended.
-  Do not position a loaded or unloaded lifter over people.
-  Before servicing a powered lifter, place the power control in the inactive position and, when possible, disconnect the power source.

OPERATING FEATURES

Features shown here are underlined> on their first appearance in each section following.

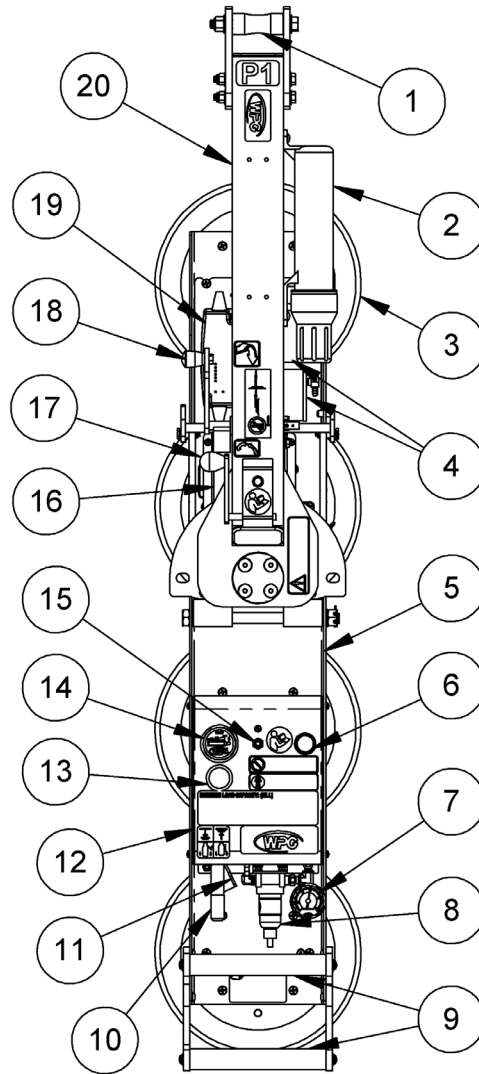

- | | | |
|---------------------------------------|-------------------------|---|
| 1 LIFT POINT | 2 INSTRUCTIONS CANISTER | 3 VACUUM PAD |
| 4 VACUUM RESERVE TANKS | 5 PAD FRAME | 6 LOW VACUUM WARNING LIGHT |
| 7 VACUUM GAUGE | 8 AIR FILTER | 9 CONTROL HANDLES |
| 10 VALVE HANDLE | 11 VALVE HANDLE LATCH | 12 Cover w/ VACUUM PUMP and VACUUM SWITCH |
| 13 LOW VACUUM WARNING BUZZER (option) | 14 BATTERY GAUGE | 15 BATTERY TEST BUTTON |
| 16 BATTERY | 17 TILT RELEASE LEVER | 18 ROTATION RELEASE LEVER |
| 19 BATTERY CHARGER | 20 LIFT BAR | |

Note: A standard P11104DC is shown here. Although some of the following photos do not show this specific lifter, they all illustrate how this kind of lifter functions.

For information about specific parts, see [“REPLACEMENT PARTS”](#) and/or any separate instructions for Product Options.

ASSEMBLY

1) Remove all shipping materials and save them with the shipping container for future use.

2) Adjust the lift point to optimize the lifter's hang angle:

2A

2.1) Remove the retaining bolt and loosen the pivot bolt (fig. 2A).

2.2) Move the lift point to the appropriate position.¹

2.3) Reinstall the retaining bolt and tighten both bolts securely.



3) Suspend the lifter from appropriate hoisting equipment:

3.1) Select a crane and/or hoist rated for the Maximum Load Capacity plus the Lifter Weight.

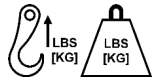

Note: Any lifter use must comply with all statutory or regulatory standards for hoisting equipment in your region.

3A



3B



3C



3.2) Disengage the tilt latch and raise the lift bar (fig. 3A-C).

1..... Moving the lift point *forward* (away from operator) helps keep the hang angle vertical while the lifter is *loaded*; moving the lift point *rearward* (towards operator) helps keep the hang angle vertical while the lifter is *unloaded*.

ASSEMBLY

3.3) Attach the hoisting hook to the lift point (fig. 3D).

! Only use rigging rated for Maximum Load Capacity plus Lifter Weight.



! Make sure hook has restraining latch (see arrow above).

Note: Use rigging (fig. 3E) as needed to make sure the hook does not interfere with the load.

3.4) Use the hoisting equipment to remove the lifter from the shipping container. Avoid damaging the vacuum pads.



4) Connect the electrical connectors (figs. 4A-B and figs. 4C-D).

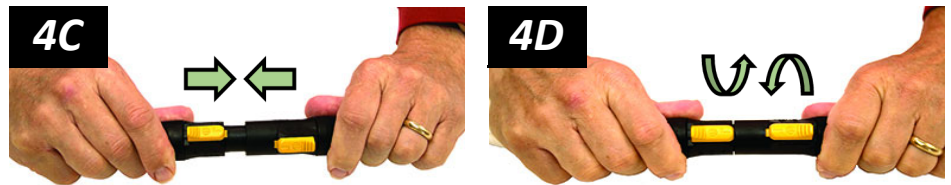

5) Remove the pad covers (fig. 5A) and save them for future use.



6) Perform tests as required under "TESTING".

INTENDED USE

LOAD CHARACTERISTICS

Make sure the vacuum lifter is intended to handle each load according to these requirements:



Do NOT lift explosives, radioactive substances or other hazardous materials.



- The load weight must not exceed the Maximum Load Capacity.
- The load must be a single piece of relatively nonporous material with a flat and relatively smooth contact surface.^{1, 2} To determine whether the load is too porous or rough, perform the “[Lifter/Load Compatibility Test](#)”.
- The load's contact surface must be able to obtain a friction coefficient of 1 with the lifter's vacuum pads (see “[Pad-to-Load Friction Coefficient](#)”). Otherwise, the capacity should be derated appropriately.
- The load's surface temperature must not exceed the Operating Temperatures.³
- The load's *minimum* length and width are determined by the current Pad Spread (see “SPECIFICATIONS”).
- The load's *maximum* length and width are determined by its allowable overhang.⁴
- 1" [2.5 cm] is the allowable thickness at Maximum Load Capacity.⁵



*Note: Standard vacuum pads can stain or deform load surfaces with light colors or soft coatings. Test such surfaces for damaging effects before using the lifter on them.*⁶

1..... Although concave vacuum pads can also attach to some curved loads, curvature can reduce lifting capacity. Contact WPG for more information.

2..... A “single piece” of material includes curtainwall assemblies, unitized glazing systems and similar construction units.

3..... Vacuum pads made from a heat-resistant rubber compound can enable you to lift loads with higher surface temperatures. Contact WPG or an authorized dealer for more information.

4..... The allowable overhang is the amount of load material that can extend sideways beyond the vacuum pads without breaking or otherwise being damaged. This depends on the load material, its thickness, and the angle of handling (if any). Since every material has different physical properties, the allowable overhang must be evaluated separately for each load type. Contact WPG or an authorized dealer for more information.

5..... However, the allowable thickness increases as load weight decreases. Contact WPG for more information.

6..... Alternative rubber compounds are available for these purposes. Contact WPG or an authorized dealer for more information.

INTENDED USE

INDIRECT LOADING

Make sure to account for dynamic loading or other inadvertent loading that can negatively affect lifting capacity, such as:

- Weight amplification that results when a loaded vacuum lifter abruptly starts/stops moving, changes direction or bounces up and down (eg, when a telehandler transports a loaded lifter across rough terrain).
- External force that effectively increases the weight of a lifter's attached load (eg, when a load of sheet material reacts to wind gusts).



Indirect loading can reduce lifting capacity.

OPERATING ENVIRONMENT

Make sure the lifter is suitable for each work environment, given the following restrictions:

- This lifter is not intended for any environment that is dangerous to the operator or damaging to the lifter. Avoid environments containing explosives, caustic chemicals and other dangerous substances.



Never use lifter in dangerous environments.



Metal particles and similar environmental contaminants could result in vacuum pump failure.

- The work environment is limited by the Operating Elevation and Operating Temperatures.^{1, 2}
- The lifter is not designed to be watertight. Do not use it in rain or other unsuitable conditions.

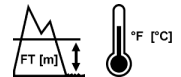

Moisture can reduce lifting capacity.

CE/UKCA — A secondary positive holding device is required to lift loads on construction sites.

DISPOSAL OF THE LIFTER

After the Service Life of the lifter has ended (see “SPECIFICATIONS”), dispose of it in compliance with all local codes and applicable regulatory standards.

Note: Special disposal regulations may apply to the battery.

1..... Although lifter use may be possible at higher elevation, lifting capacity is reduced whenever the lifter is unable to attain vacuum in the green range on the vacuum gauge. Contact WPG for more information.

2..... Special provisions may allow the lifter to operate outside the specified temperature range. Contact WPG for more information.

OPERATION

BEFORE USING THE LIFTER

Determine whether the vacuum lifter is capable of each intended task (see “SPECIFICATIONS” and “[INTENDED USE](#)”). Then complete the following preparations:

Taking Safety Precautions

- Be trained in all industry and regulatory standards for lifter operation in your region.
- Follow trade association guidelines about precautions needed for each load material.



Read all directions and safety rules before using lifter.



Always wear appropriate personal protective equipment.

Performing Inspections and Tests

- Follow the “[INSPECTION SCHEDULE](#)” and “[TESTING](#)”.
- Service the air filter whenever its bowl contains liquid or other contaminants, or its element appears dirty (see “[AIR FILTER MAINTENANCE](#)” in [SERVICE MANUAL](#)).



Examine air filter regularly and service when needed.

- If the lifter has a low vacuum warning buzzer (fig. 1A), make sure it is clearly audible at the maximum distance between the operator and the lifter, despite any barriers or obstacles.^{1, 2}



Make sure warning buzzer can be heard over noise at operator position.



1..... Maximum buzzer volume is 103 dBA at 2' [60 cm]. If CE or UKCA Standards apply, consult EN 7731 to make sure the warning buzzer is compliant.

2..... The “[Vacuum Test](#)” provides a convenient opportunity to check this.

OPERATION

Checking the Battery



Always check battery energy before every lift.

Use the battery gauge to determine whether the battery needs to be charged (see “**BATTERY RECHARGE**”).¹ Never use the lifter unless battery energy appears in the green range.

- While the valve handle is in the “attach” position (|← / power on), the battery gauge automatically shows battery energy.²
- While the valve handle is in the “release” position (|→| / power off), use the battery test button (circled) to check the battery energy.³



1..... If the vacuum pump is running or the battery charger is connected to an AC power source, the battery gauge will shown an inaccurate energy level.

2..... After the pump stops running, the battery gauge requires a few moments to stabilize before it shows an accurate energy level.

3..... If the lifter has not been used since the battery was charged, the battery gauge may falsely show a high energy level. This “surface charge” dissipates after the pump runs for about 1 minute, allowing the gauge to show accurate energy.

OPERATION

TO USE THE OPTIONAL PAD SHUTOFFS

Each pad shutoff on the pad frame controls the vacuum line to the adjacent vacuum pad. Activating or deactivating the airflow at specific pads enables the lifter to handle loads with different weights and dimensions (see “SPECIFICATIONS”) or to avoid holes in the load surface.

To support the maximum load weight and larger load dimensions, all pads must be activated; for smaller weights and dimensions, some pads may be deactivated, **provided that the lifter still has sufficient capacity to support the load** (see “LOAD CHARACTERISTICS”).



Closing any pad shutoff reduces lifting capacity.

To activate a pad, open the shutoff valve (ie, place lever *parallel* with vacuum line — fig. 1A).



To deactivate a pad, close the shutoff valve (ie, place lever *perpendicular* to vacuum line — fig. 1B).



To calculate the lifting capacity when some pads are deactivated, consult the Per-Pad Load Capacity and multiply by the number of pads currently activated. Always activate pads in a symmetrical configuration and use as many pads as possible for each load being lifted, to maximize lifting capacity and to minimize load overhang.



OPERATION

TO ATTACH THE PADS TO A LOAD

Make sure the contact surfaces of the load and vacuum pads are clean (fig. 1A — see “[Pad Cleaning](#)”).

1A



Positioning the Lifter on the Load

- 1) Center the pad frame on the load (fig. 1B).¹
- 2) Make sure all vacuum pads will fit on the load and will be loaded evenly.



Consult the Per-Pad Load Capacity.

- 3) Place the vacuum pads in contact with the load surface.

1B



1..... The lifter is designed to handle the maximum load weight when the load's center of gravity is positioned within 2" [5 cm] of the lifter's rotation axis. Uncentered loads may rotate or tilt unexpectedly.

OPERATION

Sealing the Pads on the Load

- 1) Pull the valve handle outward **until it latches** (circled in fig. 1A) in the “attach” position (⇨←).



Keep valve handle in “attach” position throughout lift.

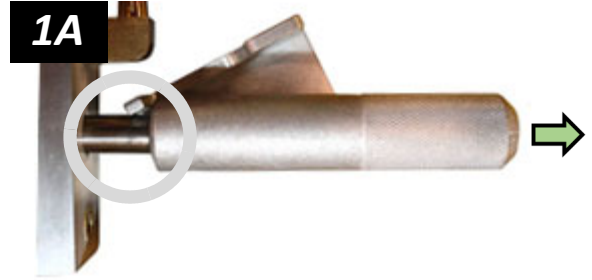

The vacuum pump will turn on, the low vacuum warning light will remain lit and the low vacuum warning buzzer, if present, will sound until the vacuum pads seal. This is normal.

- 2) Press the lifter firmly against the load to help the pads begin to seal.¹

Reading the Vacuum Gauge

A vacuum gauge shows the current vacuum level in positive inches of Hg and negative kPa:

- **Green range** (≥ 16 " Hg [-54 kPa]): Vacuum level is sufficient to lift the maximum load weight (fig. 1B).
- **Red range** (< 16 " Hg [-54 kPa]): Vacuum level is **not** sufficient to lift the maximum load weight (fig. 1C).



If it takes more than 5 seconds for the vacuum level to reach 5" Hg [-17 kPa], press on any vacuum pad that has not yet sealed.

Once the pads have sealed, the lifter should be able to maintain sufficient vacuum for lifting, except when used above the maximum Operating Elevation.² If it does not:

- Make sure the vacuum switch is adjusted correctly (see [SERVICE MANUAL](#)).
- When necessary, perform the “[Vacuum Test](#)”.

1..... Although a vacuum pad may become distorted during shipping or storage, this condition should correct itself with continued use.

2..... If the lifter is used above the maximum Operating Elevation (see “SPECIFICATIONS”), it may not be able to maintain sufficient vacuum for lifting. Contact WPG for more information.

OPERATION

To Lift and Move the Load



Lift bar must be vertical to lift load.

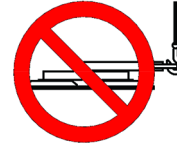
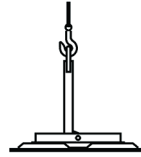

Interpreting the Warning Light and Optional Warning Buzzer



When vacuum is sufficient to lift the Maximum Load Capacity, the vacuum pump and the low vacuum warning light turn off temporarily, to conserve battery energy.



Never lift load unless warning devices turn off, because this could result in load release and personal injury.

When air leaks into the vacuum system, the vacuum pump turns on and off (along with the warning light) as necessary to maintain sufficient vacuum for lifting. *Note: The low vacuum warning buzzer, if present, turns on and off together with the warning light.*

Monitoring Vacuum Indicators

Monitor the low vacuum warning light and the vacuum gauge (fig. 1A) throughout the entire lift.

1A



Make sure vacuum indicators remain completely visible.

If the warning light turns on and the ***vacuum gauge shows a level less than 16" Hg [-54 kPa]***:

- 1) Keep everyone away from a suspended load until it can be safely lowered to a stable support.



Stay clear of any suspended load while indicators warn of low vacuum.

- 2) Stop using the lifter until the cause of the vacuum loss can be identified: Conduct the ***“Pad Inspection”*** and perform the ***“Vacuum Test”***.
- 3) Correct any faults before resuming normal operation of the lifter.



OPERATION

Controlling the Lifter and Load

When the lifter is ready, use the hoisting equipment to raise the lifter and load as needed.

Use a control handle (circled in fig. 1A) to keep the lifter and load in the required position.

Once there is enough clearance, you may move the load as required.



In Case of a Power Failure

A vacuum reserve tank helps maintain vacuum temporarily in the event of a battery failure or electrical system failure. Although the lifter is designed to support the load for at least 5 minutes without power, this depends on many factors, including the “[LOAD CHARACTERISTICS](#)” and the condition of the vacuum pads (see “[VACUUM PAD MAINTENANCE](#)”).

If a power failure occurs, keep everyone away from a suspended load until it can be safely lowered to a stable support. Correct any faults before resuming normal operation of the lifter.



Stay clear of any suspended load during power failure.

OPERATION

To ROTATE THE LOAD

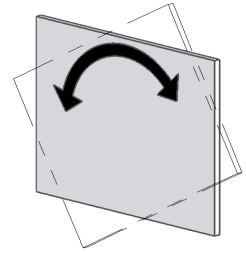

Make sure load is positioned correctly on lifter (as previously directed).



Never disengage rotation and tilt latches at the same time, because this could result in load damage or personal injury.

- 1) Make sure the load has enough clearance to rotate without contacting anyone or anything.
- 2) Use a control handle (circled in fig. 2A) to keep the load under control at all times.



Unbalanced loads may rotate unexpectedly when latch is disengaged.

- 3) Pull the rotation release lever (fig. 3A) to disengage the rotation latch, and rotate the load as required.
- 4) To stop rotation, let go of the lever and guide the load to the next stop.

Note: Whenever rotation is not required, keep the rotation latch engaged, to prevent load damage or personal injury.



OPERATION

TO TILT THE LOAD



Make sure load is positioned correctly on lifter (as previously directed).



Never disengage rotation and tilt latches at the same time, because this could result in load damage or personal injury.

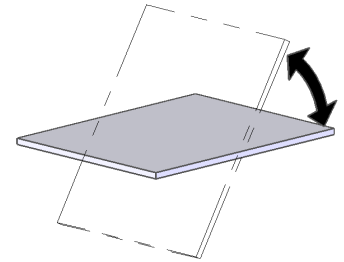

- 1) Make sure the load has enough clearance to tilt without contacting anyone or anything.
- 2) Use a control handle (circled in fig. 2A) to keep the load under control at all times.



Unbalanced loads may tilt unexpectedly when latch is disengaged.

- 3) If the pad frame is latched, pull the tilt release lever (fig. 3A) to disengage the tilt latch. Then tilt the load as required.

Note: See "LOAD CHARACTERISTICS" for information about allowable overhang.

A load with overhang may force you to release the control handle as the load approaches the flat position. In this case, use a hand cup (circled in fig. 4A) or other appropriate means to control the load.

Note: The pad frame automatically latches when tilted to the vertical position.

2A

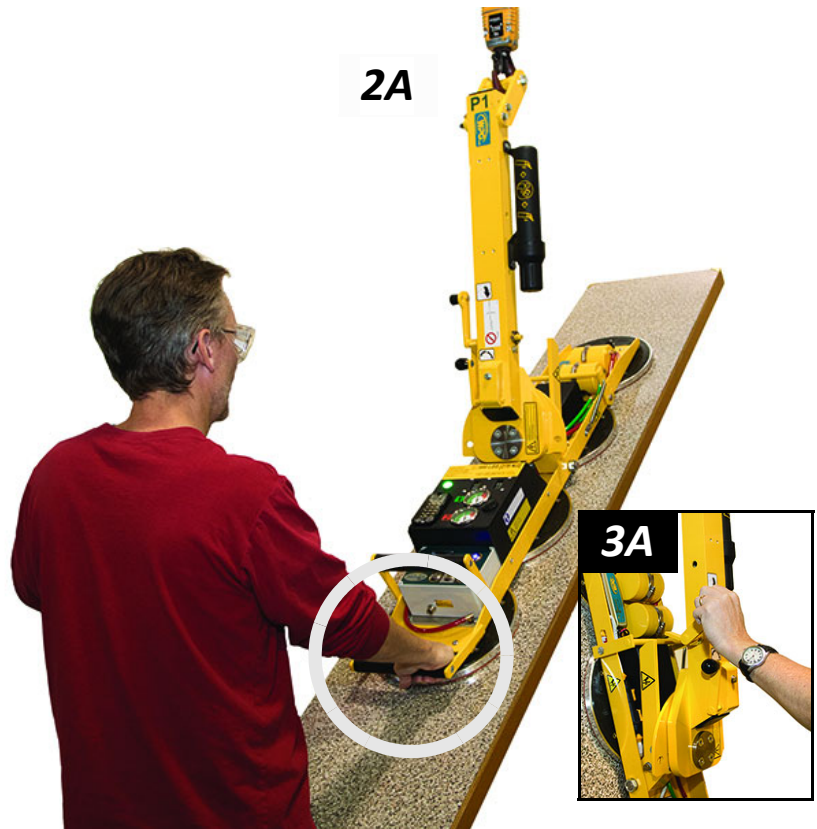

3A



4A



OPERATION

TO RELEASE THE PADS FROM THE LOAD



Make sure load is at rest and fully supported before releasing vacuum pads.

- 1) Press the lever to release the latch and push the valve handle inward (fig. 1A) to the “release” position (|→|).

1A

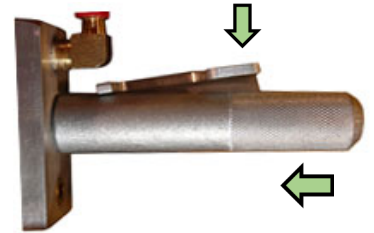

Do not move lifter until pad releases pads release completely, because such movement could result in load damage or personal injury.

- 2) Before you lift another load, perform the Every-Lift Inspection (see “[INSPECTION SCHEDULE](#)”).

AFTER USING THE LIFTER

- 1) Leave the valve handle in the “release” position (|→| / power off).
- 2) Charge the battery after each workday as needed (see “[BATTERY RECHARGE](#)”).¹
- 3) Use the hoisting equipment to lower the vacuum lifter gently onto a stable support. Then detach the hoisting hook from the lift point.

Caution: Do not set the lifter on surfaces that could soil or damage vacuum pads.

Note: A control handle can be used to support an unloaded lifter when not suspended (fig. 3A). Make sure the lifter leans securely against an appropriate support that does not contact the vacuum pads.

3A



1..... To maximize battery life, charge it promptly after each use.

OPERATION

Storing the Lifter

- 1) Use the pad covers supplied (fig. 1B) to keep the vacuum pads clean.

CE/UKCA — To prevent the lifter from tipping over on relatively horizontal surfaces, place the vacuum pads facedown on a clean, smooth, flat surface. Then lower the lift bar and place a support under the lift point.



- 2) Charge the battery completely and repeat every 6 months (see “[BATTERY RECHARGE](#)”).

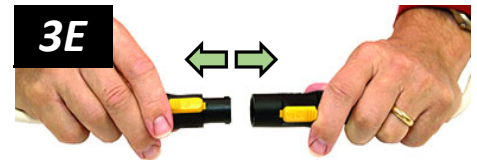
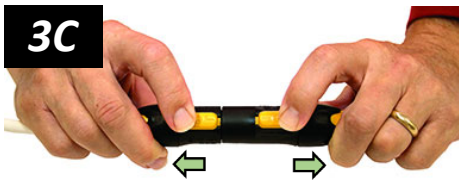
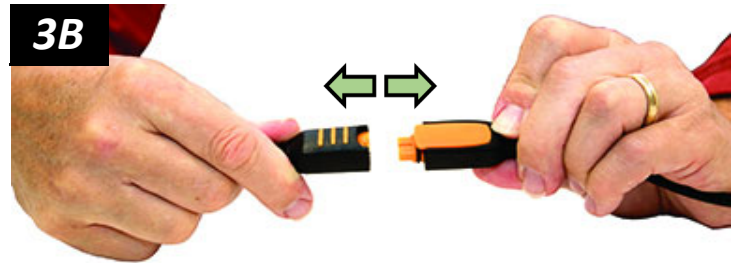

- 3) Disconnect the electrical connectors (figs. 3A-B and figs. 3C-E), to prevent battery discharge.
- 4) Store the lifter in a clean, dry location. Store the battery between 32° and 70° F [0-21° C]. Avoid storage above 100° F [38° C].

Transporting the Lifter

Secure the lifter in the original shipping container with the original shipping materials or equivalent.

INSPECTIONS AND TESTS

INSPECTION SCHEDULE

Perform inspections according to the following frequency schedule. If any fault is found, correct it and perform the next most frequent inspection before using the vacuum lifter.

Note: If a lifter is used less than 1 day in a 2-week period, perform the Periodic Inspection before using it.

Action	Every Lift	Frequent ¹ (every 20-40 hrs)	Periodic ² (every 250-400 hrs)
Examine <u>vacuum pads</u> for contaminants or damage (see “ Pad Inspection ”).	✓	✓	✓
Examine load surface for contaminants or debris.	✓	✓	✓
Examine controls and indicators for damage.	✓	✓	✓
Check <u>battery</u> for adequate charge (see “ Checking the Battery ”).	✓	✓	✓
Examine lifter’s structure for damage.		✓	✓
Examine vacuum system for damage (including <u>vacuum pads</u> , fittings and hoses).		✓	✓
Examine <u>air filter</u> for conditions requiring service (see “AIR FILTER MAINTENANCE” in SERVICE MANUAL).		✓	✓
Perform “ Vacuum Test ”.		✓	✓
Check for unusual vibrations or noises while operating lifter.		✓	✓
Examine entire lifter for evidence of: <ul style="list-style-type: none"> • looseness, excessive wear or excessive corrosion • deformation, cracks, dents to structural or functional components • cuts in vacuum pads or hoses • any other hazardous conditions 			✓
Inspect entire electrical system for damage, wear or contamination that could be hazardous, in compliance with all local codes and regulatory standards. <i>Caution: Use appropriate cleaning methods for each electrical part, as specified by codes and standards. Improper cleaning can damage parts.</i>			✓

1..... The Frequent Inspection is also required whenever the lifter has been out of service for 1 month or more.

2..... The Periodic Inspection is also required whenever the lifter has been out of service for 1 year or more. Keep a written record of all Periodic Inspections. If necessary, return the lifter to WPG or an authorized dealer for repair (see “[REGISTRATION AND LIMITED WARRANTY](#)”).

TESTING

Perform the following test to determine whether or not a load surface is too porous or rough:

Lifter/Load Compatibility Test¹

- 1) Make sure the vacuum generating system is functioning correctly (see “Vacuum Test”).
- 2) Clean the load surface and the vacuum pads (see “Pad Cleaning”).²
- 3) Place the load in the upright position on a stable support.
- 4) Attach the vacuum pads to the load as previously directed.
- 5) After the vacuum pump stops running, disconnect the battery connector (see “AFTER USING THE LIFTER”).³
- 6) Raise the load a minimal distance, to make sure it is supported by the lifter.
- 7) Watch the vacuum gauge: **Starting from a vacuum level of 16" Hg [-54 kPa], the lifter must maintain a vacuum level greater than 12" Hg [-41 kPa] for 5 minutes.**⁴ If not, lifting this load requires additional precautions (eg, a load sling). Contact WPG for more information.
- 8) Lower the load *after* 5 minutes or *before* the vacuum level diminishes to 12" Hg [-41 kPa].



Take precautions in case load should fall during test.

1..... The “Pad-to-Load Friction Coefficient” can affect the outcome of this test.

2..... Contaminated loads can cause the vacuum pump to run frequently or continuously. Since excessive pumping quickly reduces battery energy, clean the load whenever possible.

3..... Move the valve handle to the “release” position (power *off*) before reconnecting the battery.

4..... Under CE and UKCA requirements, the lifter must maintain a vacuum level **greater than 8" [-27 kPa]**.

INSPECTIONS AND TESTS

Perform the following tests before placing the lifter in service *initially, following any repair,* when directed in the “*INSPECTION SCHEDULE*”, or *whenever necessary*:

Operational Tests

Test all features and functions of the lifter (see “OPERATING FEATURES” and “OPERATION”).

Vacuum Test

- 1) Clean the face of each vacuum pad (see “*Pad Cleaning*”).
- 2) Use a test load with weight equal to the Maximum Load Capacity, a clean, smooth, nonporous surface and other appropriate “*LOAD CHARACTERISTICS*”.¹ 
- 3) Attach the lifter to the test load as previously directed. After the vacuum pump stops running, the vacuum level should appear in the green range on the vacuum gauge (if not, see “VACUUM SWITCH ADJUSTMENT” in *SERVICE MANUAL*).
- 4) Raise the load a minimal distance and disconnect the battery connector (see “*AFTER USING THE LIFTER*”).²

 **Take precautions in case load should fall during test.**
- 5) Watch the vacuum gauge: *The vacuum level should not decrease by more than 4" Hg [-14 kPa] in 5 minutes.*
- 6) Lower the load after 5 minutes or whenever a lifter fails the test, and release the load as previously directed.

 **Never use lifter that has failed test.**
- 7) Qualified service personnel must correct any fault in the vacuum system before the lifter can be returned to service.

 **This service must be performed by qualified service personnel.**

1..... The load should have either a flat surface or no more curvature than the lifter is designed for, if any.

2..... Move the valve handle to the “release” position (power *off*) before reconnecting the battery.

INSPECTIONS AND TESTS

Rated Load Test¹

The following steps must be performed or supervised by a qualified person:²

- 1) Use a test load that weighs 125% ($\pm 5\%$) of the Maximum Load Capacity and has the appropriate “LOAD CHARACTERISTICS”. 
- 2) Attach the vacuum pads to the load as previously directed.
- 3) Position the load to produce the greatest stress on the lifter consistent with “INTENDED USE”.
- 4) Raise the load a minimal distance and leave it suspended for 2 minutes.
- 5) Once the test is completed, lower and release the load as previously directed.
- 6) Inspect the lifter for any stress damage, and repair or replace components as necessary to successfully pass the test.
- 7) Prepare a written report of the test and keep it on file.



Take precautions in case load should fall during test.



Never use lifter that has failed test.

1..... An equivalent simulation may also be used. Contact WPG for more information.

2..... A “qualified person” has successfully demonstrated the ability to solve problems relating to the subject matter and work, either by possessing a recognized degree in an applicable field or a certificate of professional standing, or by possessing extensive knowledge, training and experience.

MAINTENANCE

Note: Refer to **SERVICE MANUAL #36110** when applicable.

VACUUM PAD MAINTENANCE

Pad-to-Load Friction Coefficient

The friction coefficient represents the lifter's ability to resist load slippage. The Maximum Load Capacity is based on a friction coefficient of 1, as determined by testing of clean, new, standard rubber vacuum pads on clean, dry, regular glass. **If the lifter is used under any other conditions, a qualified person must first determine the effective lifting capacity.**¹



Long-term exposure to heat, chemicals or UV light can damage vacuum pads. Replace pads every 2 years or more often when necessary.

Pad Inspection

Inspect each vacuum pad (fig. 1A) according to the “**INSPECTION SCHEDULE**” and correct the following faults before using the lifter (see “**REPLACEMENT PARTS**”, when applicable):

- Contaminants on the face (item 1 in fig. 1A) or sealing edges (item 2 in fig. 1A).
- Filter screen (item 3 in fig. 1A) missing from face.



Replace any pad that has damaged sealing edges.

- Nicks, cuts, deformation or abrasions in sealing edges.
- Wear, stiffness or glaze.

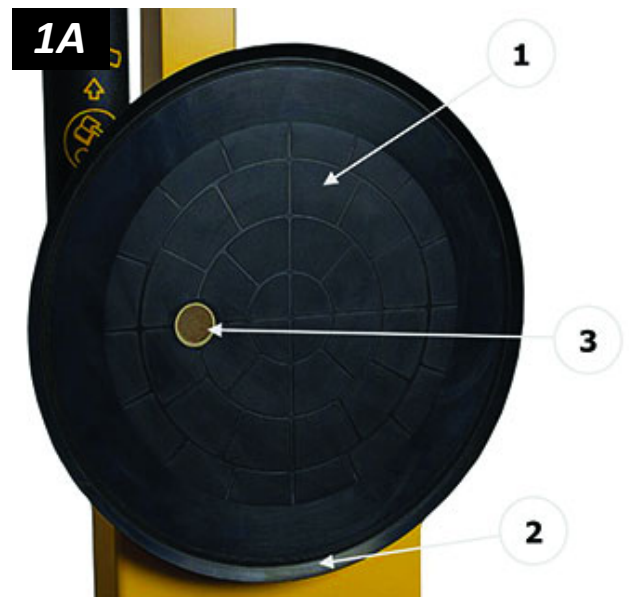

1..... A “qualified person” has successfully demonstrated the ability to solve problems relating to the subject matter and work, either by possessing a recognized degree in an applicable field or a certificate of professional standing, or by possessing extensive knowledge, training and experience.

Pad Cleaning

- 1) Regularly clean the face of each vacuum pad (fig. 1A), using soapy water or other mild cleansers to remove oil, dust and other contaminants.



Never use harsh chemicals on vacuum pad.

Solvents, petroleum-based products (including kerosene, gasoline and diesel fuel) or other harsh chemicals can damage vacuum pads.



Never use rubber conditioners on vacuum pad.

Many rubber conditioners can leave a hazardous film on vacuum pads.

- 2) Prevent liquid from entering the vacuum system through the suction hole on the pad face.
- 3) Wipe each pad face clean, using a clean sponge or lint-free cloth to apply the cleanser.¹
- 4) Allow each pad to dry completely before using the lifter.

1A



¹..... A brush with bristles *that do not harm rubber* can help remove contaminants clinging to sealing edges. If these cleaning methods are not successful, contact WPG or an authorized dealer for assistance.

BATTERY RECHARGE

Charge the battery whenever the battery gauge shows reduced energy.¹ **Caution:** Make sure valve handle is in “release” position (|→ | / power off).

Identify the input voltage marked on the battery charger, and plug it in to an appropriate power source.²



Make sure power source has ground fault circuit interrupter.

The power lamp (Φ) turns on when the charger is functioning. Consult the six-stage display to determine the charging status. The battery can be used after stage 3 and is fully charged at stage 5.

Normally, the battery should take no more than 8 hours to charge completely.³ If not, check for the following faults:

- Power lamp (Φ) flashes: Charger is not connected to battery; reconnect charger (see “ASSEMBLY”).
- Error lamp (!) turns on immediately: Battery leads connected to wrong poles; reverse battery leads.
- Charging stops at stage 1 or 4, and error lamp (!) turns on: Battery is no longer functioning; replace battery (see “REPLACEMENT PARTS”).

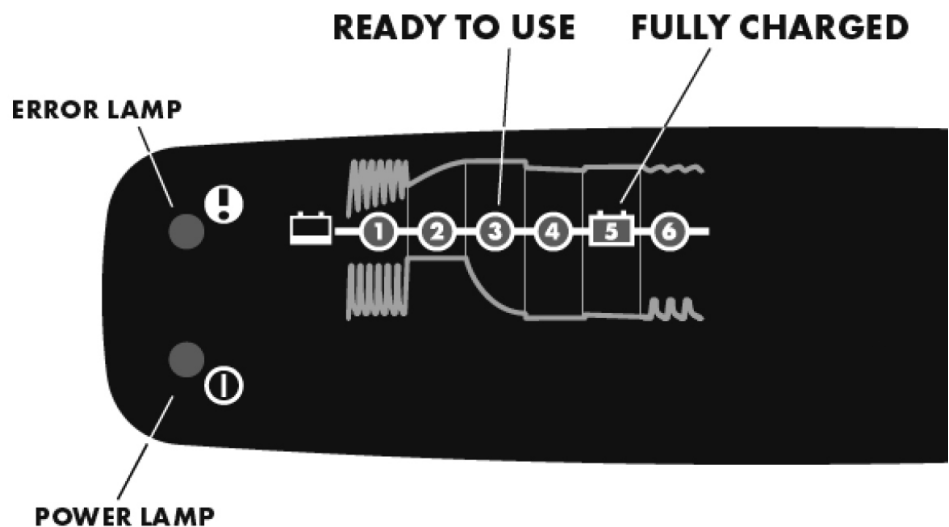

Before you return the lifter to service, recheck the battery as previously directed.

1..... To maximize the battery's lifespan, charge it promptly after each use.

2..... Any external power supply must conform to all applicable local codes. The lifter is not intended for use while the charger is connected to AC power.

3..... The charger automatically reduces the charging rate when the battery is fully charged.

REPLACEMENT PARTS

Stock No.	Description	Qty.
93012	Pad Shutoff Valve Assembly	4
65440	Vacuum Hose – 0.245" ID x 3/8" OD – Red	*
64716	Battery Charger – 0.8 Amp – 240 V AC – Australian Type	1
64715	Battery Charger – 0.8 Amp – 240 V AC	1
64714	Battery Charger – 0.8 Amp – 100 / 120 V AC	1
64664	Battery – 12 V DC – 7 Amp-Hours	1
64283	Bulb – 13 V – Bayonet (for low vacuum warning light)	1
59086NC	Battery Connector – Twin Lead	1
57012	Pad Channel Tilt Pin	1
54390NC	Power Lead	1
53132	Hose Fitting – Tee – 5/32" ID	2
53126	Pad Fitting – Tee – 3/64" ID	2
53120	Pad Fitting – Elbow – 3/64" ID	2
49646T	Vacuum Pad – Model G3370 / 11" [28 cm] Diameter – Lipped	4
49605T	Vacuum Pad – Model HV11 / 10" [25 cm] Diameter – Lipped	4
49586TA	Vacuum Pad – Model G0750 / 10" [25 cm] Diameter – Concave	4
49130	End Plug – 2" x 3" x 1/4" Tubing Size	2
36110	Service Manual – 12 V DC – 1 SCFM – Single Vacuum System – Manual Valve	1
29353	Pad Cover	4
15792	Rotation Release Lever Knob	1
15632	Pad Filter Screen – Small (for G0750 pad)	4
15630	Pad Filter Screen – Large (for G3370 & HV11 pads)	4
10005	Machine Screw – 1/4-20 x 1" (for HV11 pad mounting)	**
10003	Machine Screw – 1/4-20 x 3/4" (for pad mounting)	**
10002	Machine Screw – 1/4-20 x 1/2" (for pad mounting)	**

* – Length as required; sold by the inch (approx 2.5 cm)

** – Quantity as required

See **SERVICE MANUAL #36110** for additional parts.

**SERVICE ONLY WITH IDENTICAL REPLACEMENT PARTS,
AVAILABLE AT WPG.COM OR THROUGH AN AUTHORIZED WPG DEALER**

REGISTRATION AND LIMITED WARRANTY

TO REGISTER THIS WPG PRODUCT

Go to the [PRODUCT REGISTRATION](#) page at [wpg.com](#) and complete the form. Registration keeps you advised of important updates and notifications, and simplifies inquiries to WPG regarding your product. Registration is **not** required to activate your Limited Warranty (see next section).

ABOUT THE LIMITED WARRANTY



Note: Read the [WARRANTY RETURN FORM](#) at [wpg.com](#) for important details about the Limited Warranty.

Wood's Powr-Grip® (WPG) products are warranted to be free from defects in manufacturing and materials for 1 year from the date of purchase.

If a problem develops during the warranty period, follow the instructions below to obtain warranty service. If inspection shows that the product has a defect, WPG will repair or replace the product without charge.



Obtaining Warranty Service or Repair Service

For customers in the U.S. and Canada: Go to the [EXCHANGES, REPAIRS, & WARRANTIES](#) page at [wpg.com](#) and click the applicable link. Alternatively, you may contact the WPG Technical Service Department (see contact information at right).

For customers in all other localities: Contact the WPG Technical Service Department (see contact information at right) or your dealer for assistance.

Address:

Wood's Powr-Grip Co., Inc.
908 West Main St.
Laurel, MT 59044 USA

Email:

contactus@wpg.com

Phone:

800-548-7341 or 406-628-8231

KEEP FOR FUTURE REFERENCE

ENGINEERING DRAWINGS

 INTENDED FOR USE BY QUALIFIED SERVICE
PERSONNEL • READ AND UNDERSTAND BEFORE
ROUTING, WIRING AND/OR ASSEMBLING



908 W. Main • P.O. Box 368
Laurel, MT USA 59044
800-548-7341 • 406-628-8231
www.WPG.com

**SINGLE-CHANNEL LIFTER,
DC-VOLTAGE**

Model numbers: P110C04DC, P1HV1104DC, P111104DC

TYPE: STANDARD

WIRE LEGEND: CONTROLLED BY WIRING SYMBOLS DRAWING EXCEPT AS NOTED AND BELOW. LINE STYLES AND WIDTHS FOR WIRE UNLESS NOTED OTHERWISE.

NOTES:
1) 16AWG OR 20AWG WIRE, BASED ON VACUUM PUMP USED.

DIRECTORY: H:\Working\STD\705-DCP\JUECN 3011\705-W01 [D-W01]

WOOD'S POWER-GRIP CO., INC.
LAUREL, MONTANA U.S.A.

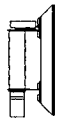

1 SCFM DC VACUUM PACKAGE

PIEZOELECTRIC BUZZER WIRING DIAGRAM
D705-W01 [D-W01]

DRAWN: L. RENNER
DATE: 06/04/2003
CHECKED: *dl*
APPROVED: *Allen*

SIZE: A NONE
SCALE: NONE
REV: 4
ECN NUMBER: 3011
DATE: 11/14/2012
BY: RAS
EST. WEIGHT: N/A

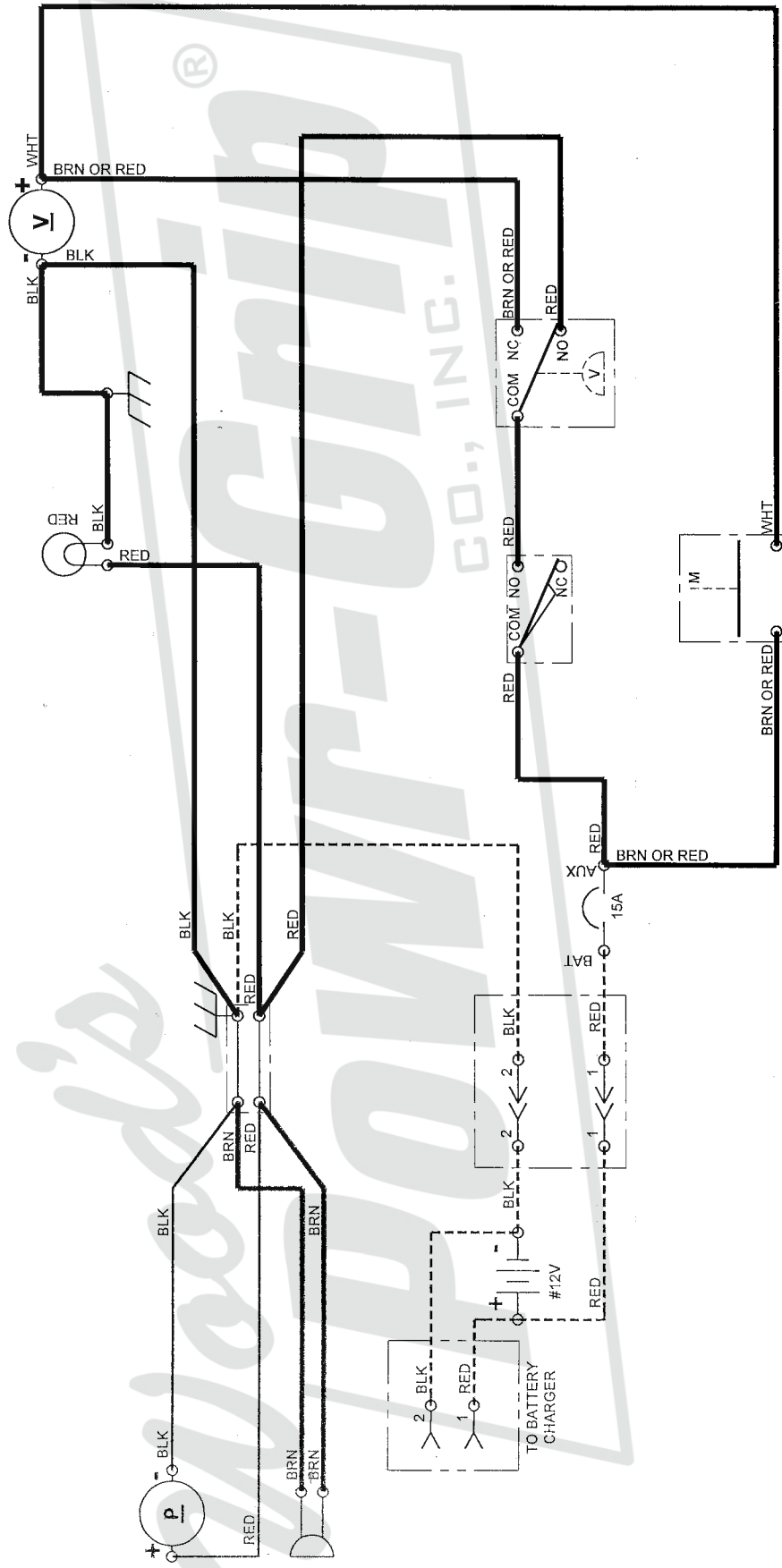

TOLERANCES: CONTROLLED BY STANDARD D105C001 EXCEPT AS NOTED AND LISTED BELOW.		FILE DIRECTORY: 705- W04 [W04]	
DECIMAL X.XX ± N/A	ANGULAR X° ± N/A	FRACATIONAL X/XX ± N/A	TYPE: STANDARD
X.XXX ± N/A	Ø .1" ± N/A	Ø .1" ± N/A	THIS DRAWING IS THE PROPERTY OF WOOD'S POWER-GRIP CO., INC. LAUREL, MONTANA U.S.A.
Ø X.XXX ± N/A	Ø .1" ± N/A	Ø X/XX ± N/A	WPG
PRODUCT MANAGER: KEITH B.	DATE: 10/10/2016	1 SCFM DC VACUUM PACKAGE	
CHECKED: <i>al</i>	10-18-16	N/A	
APPROVED: <i>amr</i>	10-18-16	CHARGER WIRING SCHEMATIC	
		SIZE: A	REVISION: 01.A
		SCALE: NONE	ECN NUMBER: 4151
			ECN DATE: 10/10/2016
			ECN BY: JAC
			EST. WEIGHT: N/A

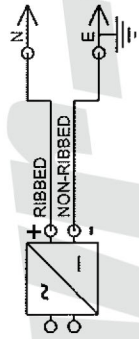
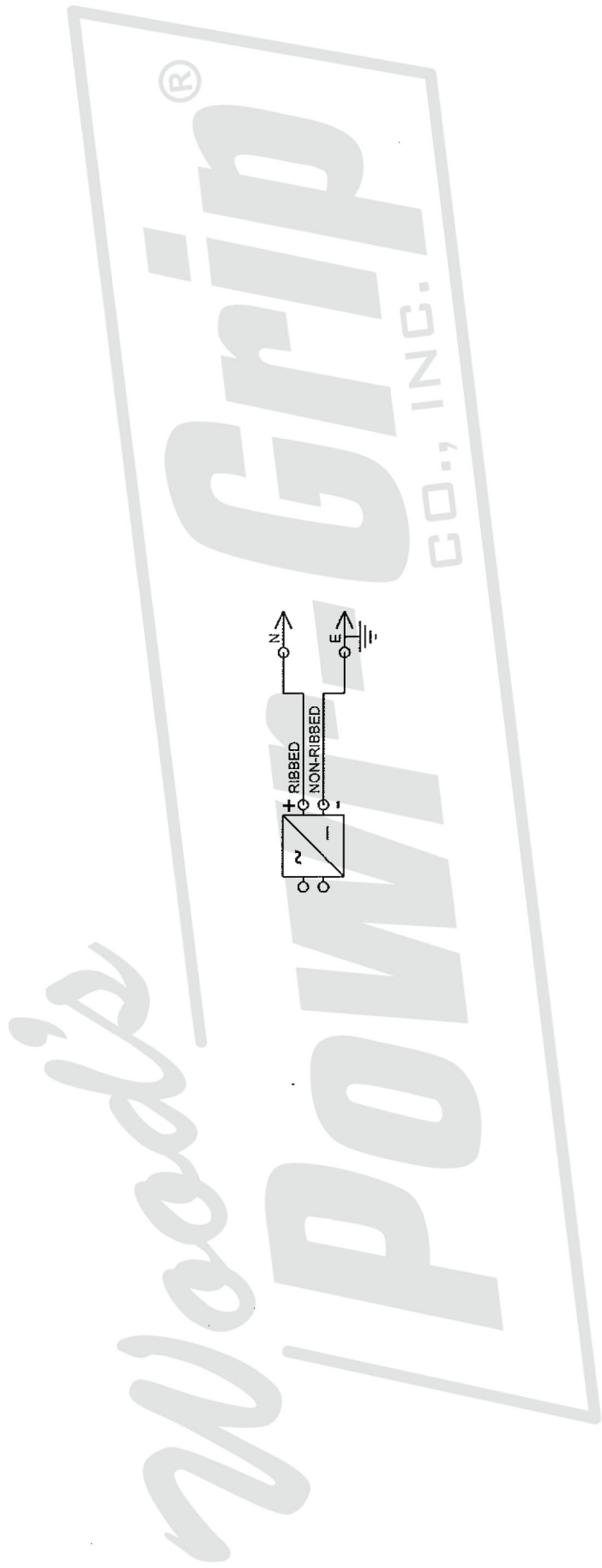

FILE DIRECTORY:
STANDARD

FILE (SHEET):
705-W06 [W06]

WIRE LEGEND: CONTROLLED BY
WIRING SYMBOLS DRAWING
EXCEPT AS NOTED AND BELOW.

LINE STYLES AND WIDTHS FOR
WIRE UNLESS NOTED OTHERWISE.
N/A N/A
18AWG 18AWG
16AWG 16AWG

PRODUCT MANAGER:
KEITH B.
DATE: 10/27/2016
CHECKED:
APPROVED: *Chm*
11-30-16
11-30-16



THIS DRAWING IS THE PROPERTY OF
WOOD'S POWER-GRIP CO., INC.
IT IS LOANED WITH THE UNDERSTANDING THAT NEITHER IT NOR ANY
INFORMATION CONTAINED THEREIN WILL BE COPIED, PUBLISHED OR
TRANSMITTED TO OTHERS WITHOUT EXPRESS WRITTEN PERMISSION.
LAUREL, MONTANA U.S.A.



1 SCFM DC VACUUM PACKAGE
N/A

1 SCFM DC VACUUM SYSTEM WIRING SCHEMATIC, POWERCON
D705-W06 [W06]

SIZE: SCALE: A NONE REVISION: 02.A ECN NUMBER: 4170 ECN DATE: 11/02/2016 ECN BY: JAC EST. WEIGHT: N/A

NOTES:
(1) 16 AWG OR 20 AWG WIRE, BASED ON VACUUM PUMP USED.

